



OPERATING AND SERVICE INSTRUCTIONS

---

**COMMUNICATIONS  
RECEIVER  
MODEL SX-130**

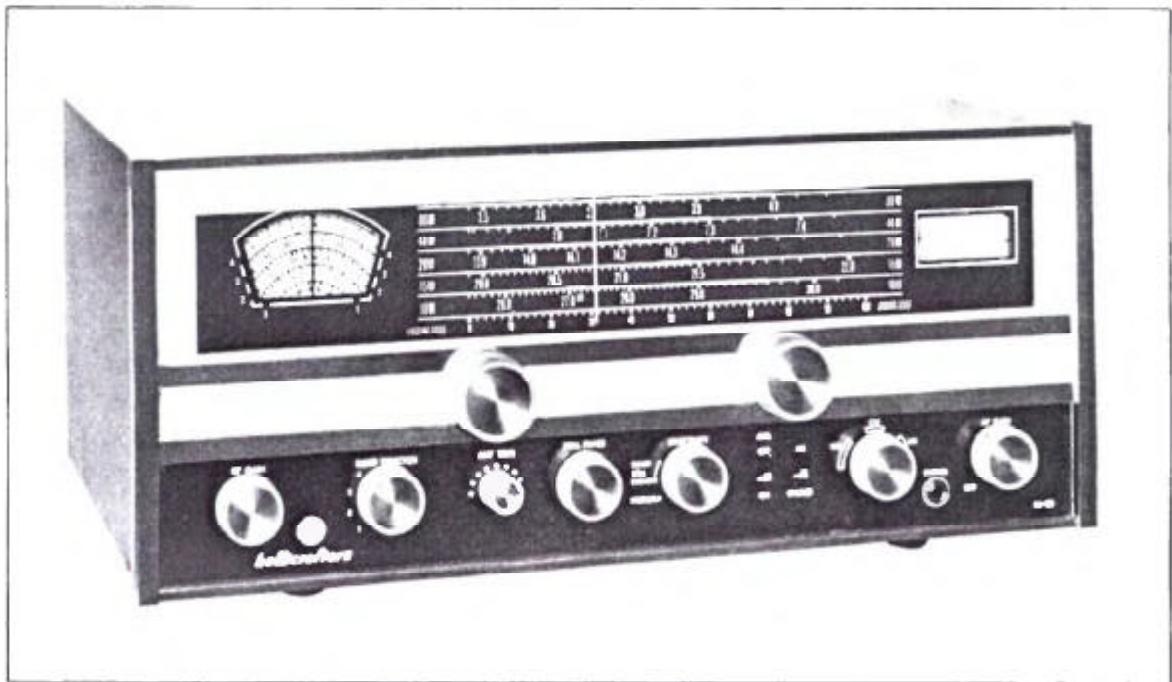

Figure 1. Hallicrafters' Model SX-130 Receiver.

130-00687

## SECTION I GENERAL DESCRIPTION

The Hallicrafters' Model SX-130 Communications Receiver is a four band superheterodyne receiver tuning from 535 to 1610 kilocycles (KC) and 1.725 to 31.5 megacycles (MC) with calibrated electrical bandspread provided on the 80, 40, 20, 15, 10 meter and citizens band. The frequency range covers foreign and domestic short-wave broadcasts, amateurs, aircraft, and marine plus standard AM broadcasts. The receiver provides for the reception of code (CW), voice (AM), and single-sideband (SSB) signals over its entire tuning range, the upper or lower sideband being readily selectable by means of a front panel control. This feature greatly simplifies tuning of single-sideband signals.

Other features of the Model SX-130 include:

- Product detector for CW and SSB.
- Slide rule bandspread dial.
- Separate bandspread tuning condenser.
- Crystal filter.
- Antenna trimmer for maximum signal transfer.
- "S" meter to indicate the accuracy of tuning and the relative strength of received signals.
- Front panel controlled automatic noise limiter reduces interference from electrical equipment, ignition noise, etc.
- Calibrated BFO for USB-LSB-CW.
- Crystal phasing control for precise bandwidth adjustment.
- Manual RF gain control prevents overloading by strong signals.
- Precision tuning mechanism insures close calibration and accurate resettability.
- Balanced or unbalanced antenna inputs.
- New, handsomely styled cabinet.

## SECTION II TECHNICAL SPECIFICATIONS

### Frequency Coverage

Band 1	.....	535 KC to 1610 KC
Band 2	.....	1.725 MC to 4.7 MC
Band 3	.....	4.5 MC to 13.0 MC
Band 4	.....	11.9 MC to 31.5 MC

Intermediate Frequency..... 1650 KC

Reception Modes..... AM, CW and SSB

Selectivity..... Variable in three steps; normal, crystal broad and crystal sharp

Power Source..... 105 to 125 volts, 50/60 cycles

Power Consumption..... 48 watts

Audio Power Output..... 2 watts

Audio Output Impedance..... 3.2 ohms; rear mounted screw terminals

Headphone Impedance..... 50 to 2000 ohms; panel jack accepts standard 1/4 inch phone plug

Antenna Input Impedance..... 50 to 600, balanced or unbalanced

Number of Tubes..... Seven, plus one diode

Receive/Standby..... Rear mounted screw terminals; short to receive, open for standby

Dimensions..... 8 inches high, 18-7/8 inches wide, 9-3/4 inches deep

Net Weight..... 22 pounds

Shipping Weight..... 25 pounds

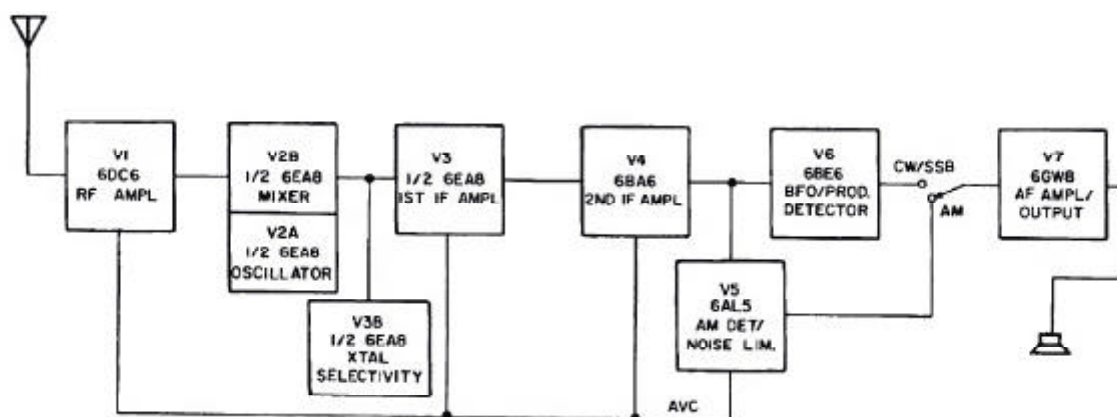

Figure 2. Block Diagram of Receiver.

154-006126



## SECTION III INSTALLATION

### 3-1. UNPACKING.

Carefully remove this equipment from its carton and packing material and examine it for any possible damage which may have occurred in transit. Should any sign of damage be apparent, file a claim immediately with the carrier stating the extent of damage. Carefully check all shipping labels and tags before removing or replacing them.

### 3-2. LOCATION.

The receiver may be placed in any location that will permit free air circulation around the cabinet. Avoid excessively warm locations such as those near radiators and heating vents. Also, avoid direct blasts of air from circulating fans, etc.

### 3-3. ANTENNAS.

The Model SX-130 uses an input circuit designed for a 52 to 600 ohm input. Any of the popular dipole, beam antennas or single wire antennas will give good results. It should be remembered, however, that these antennas will give optimum results over a limited frequency range. Generally speaking, the same rules that apply to transmitting antennas will hold true for receiving antennas. If an unbalanced or a single

wire antenna is used, connect one end to the terminal marked A1. The jumper link should be connected between A2 and G (see figure 3). For further information on this subject, refer to the "Radio Amateur's Handbook" or the "ARRL Antenna Book", both published by the American Radio Relay League.

### 3-4. GROUNDS.

All station equipment should be bonded together with heavy copper wire or braid and connected to a cold water pipe or earth ground. An external chassis ground terminal is provided on the SX-130 rear chassis apron for this purpose.

### 3-5. POWER SOURCE.

The SX-130 is designed to operate from a 105/125 volt, 50/60 cycle AC power source. Power consumption is 48 watts.

#### NOTE

If in doubt about your power source, contact your local power company prior to inserting the power cord into any power outlet. Plugging the power cord into the wrong source can cause extensive damage to the unit.

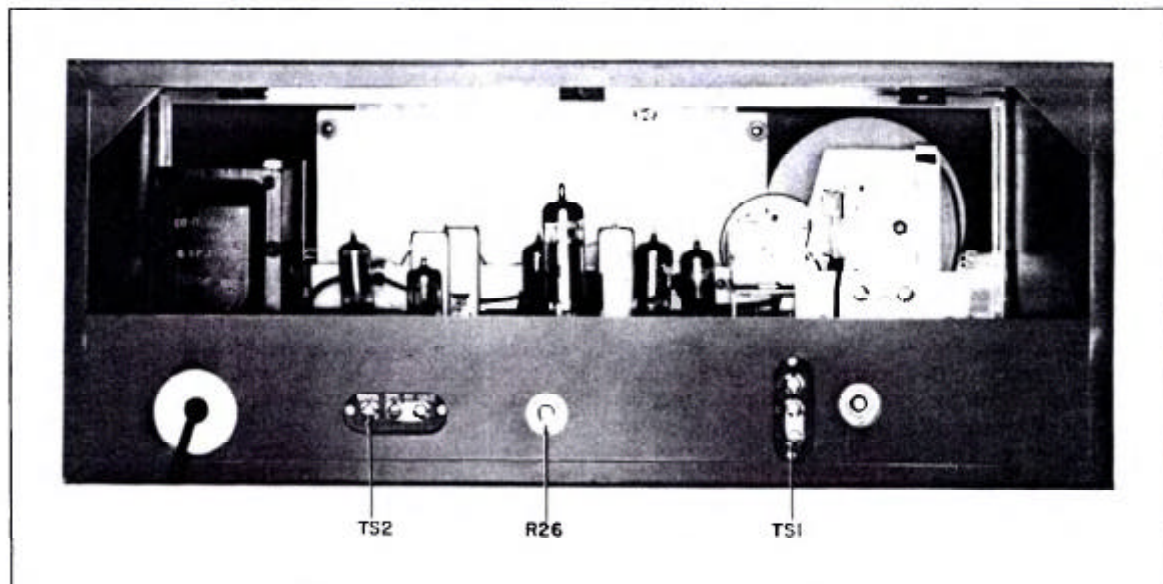

Figure 3. Rear View of Receiver.

156-006218-2

#### 4.2. BAND SELECTOR SWITCH.

The BAND SELECTOR switch is a four position rotary switch, which is used to place the proper set of coils into the circuit to cover the desired frequency range. The range of frequencies covered for each setting of the switch is shown in the following chart.

<u>SWITCH POSITION</u>	<u>FREQUENCY</u>
1	535 KC — 1610 KC
2	1,725 MC — 4.7 MC
3	4.5 MC — 13 MC
4	11.9 MC — 31.5 MC

#### 4.3. ANT TRIM CONTROL.

The ANT TRIM control is a variable capacitor connected across the secondary of the antenna coil in use. The capacitor adjustment compensates for the loading effects of various types of antennas. This control should always be peaked for maximum signal increase after the desired signal has been tuned in.

#### 4.4. XTAL PHASE CONTROL.

This control is to be used with the SELECTIVITY switch for maximum rejection of unwanted signals. Adjust for best reception, when using BROAD or SHARP XTAL selectivity positions.

#### 4.5. SELECTIVITY CONTROL.

This is a three position switch for selecting the intermediate frequency bandwidth required for different reception modes.

Recommended settings are:

NORMAL	Full fidelity AM
BROAD XTAL	SSB, or AM under adverse conditions
SHARP XTAL	CW

#### 4.6. ANL ON/OFF SWITCH.

The ANL switch is normally kept in the OFF position and used when necessary to eliminate impulse noise in AM reception. The switch does not function when receiving CW or SSB.

#### 4.7. AM-CW/SSB SWITCH.

In the AM position the switch connects the AM detector to the AF amplifier and disables the BFO. In the CW/SSB position the switch connects the product detector to the AF amplifier and energizes the BFO.

#### 4.8. USB-CW-LSB CONTROL.

This control establishes the frequency necessary for proper recovery of upper sideband, CW (code), or lower sideband signals. After the desired signal has been tuned in, this control may be used for fine tuning to establish the desired voice or code pitch. The control is not used for AM reception.

For single sideband reception, this control will usually be set as follows:

80 and 40 meters	— LSB
20, 15 and 10 meters	— USB

#### 4.9. AF GAIN-ON/OFF CONTROL.

The AF GAIN control turns power on and off, also, adjusts the audio output level in the speaker or headphones. Clockwise rotation increases the signal voltage applied to the grid of the AF amplifier, thus increasing the audio output.

#### 4.10. TUNING AND BANDSPREAD CONTROLS.

These controls are used in conjunction with one another to tune the desired signal frequency. Wide tuning is performed with the TUNING control and fine tuning may be done with the BANDSPREAD control.

##### MAIN TUNING DIAL.

The main tuning, or left hand dial, is operated by the TUNING control. The dial has four calibrated scales covering the following ranges:

BAND 1 . . . . .	535 to 1610 KC
BAND 2 . . . . .	1,725 to 4.7 MC
BAND 3 . . . . .	4.5 to 13.0 MC
BAND 4 . . . . .	11.9 to 31.5 MC

Also, a 0 to 100 scale is provided for accurately logging and relocating stations of special interest.

##### IMPORTANT

The main dial calibration will be correct only when the bandspread pointer is set at the extreme right (100 on the bandspread logging scale).

##### BANDSPREAD DIAL.

The bandspread, or right hand dial, is operated by the BANDSPREAD control. This dial



contains five scales calibrated for the 80, 40, 20, 15 and 10 meter amateur bands plus the citizens band. Also, a 0 to 100 logging scale is provided.

When the main tuning dial is set to the dot appearing just above the high frequency end of a particular amateur band, the frequency may then be read directly on the bandspread dial. For convenience in operation, the CW portion of each amateur band is indicated by a double weight line and the phone portion by a triple weight line. The dot used for 10 meters should also be used to establish bandspread calibration for the 11 meter citizens band.

The bandspread dial may also be utilized as a fine tuning adjustment over any portion of the

receiver tuning range. Two methods of fine tuning are described below.

1. The first method of fine tuning is used when it is desired to tune in a single signal accurately. First the BANDSPREAD control is set a few degrees from its full clockwise position. Then the signal is located with the MAIN TUNING control, and finally the signal is accurately tuned by "rocking" the BANDSPREAD control for best reception.

2. The second method of fine tuning is used when it is desired to tune through a group of signals. With the BANDSPREAD control set fully clockwise, adjust the TUNING control to the highest frequency signal in the group. The other signals may then be received by slowly turning the BANDSPREAD in a counterclockwise direction.

## SECTION V OPERATION

### 5-1. AM RECEPTION.

Set the front panel controls as outlined below:

RF GAIN . . . . . Maximum clockwise  
BAND SELECTOR . . . . . Desired band  
AF GAIN . . . . . As required  
ANT TRIM . . . . . Peak on signal  
ANL . . . . . OFF  
AM-CW/SSB . . . . . AM  
SELECTIVITY . . . . . NORMAL or BROAD  
TUNING and BANDSPREAD . . . . . As desired

Turn the receiver on by rotating the AF GAIN control clockwise until a click is heard. The tuning dials will light up, indicating the receiver is operative. Rotate the AF GAIN control for the desired volume level.

### 5-2. SINGLE-SIDEBAND RECEPTION.

Set the front panel controls as outlined below:

RF GAIN . . . . . Maximum clockwise  
BAND SELECTOR . . . . . Desired band  
AF GAIN . . . . . As required  
ANT TRIM . . . . . Peak on signal  
AM-CW/SSB . . . . . CW/SSB  
SELECTIVITY . . . . . NORMAL OR XTAL BROAD

XTAL PHASE . . . . . For best results  
USB-CW-LSB . . . . . Usually LSB for 40 and 80  
meters; USB for 20, 15 and  
10 meters  
TUNING AND BANDSPREAD . . . . . As desired

Turn the receiver on by rotating the AF GAIN control clockwise until a click is heard. The tuning dial will light up, indicating the receiver is operative. Rotate the AF GAIN control for the desired volume level.

It should be remembered that an SSB signal will convey intelligence only when the correct sideband position has been selected by the USB-CW-LSB control. If the signal does not tune properly, move the USB-CW-LSB control to the opposite sideband position and retune the receiver.

Under certain conditions, it may be found advantageous to reduce the RF GAIN setting for improved reception. It should be remembered that this will reduce AVC and also affect the "S" meter reading.

### 5-3. CW RECEPTION.

Set all controls as shown in single-sideband reception, except for the USB-CW-LSB control which should be set to the CW position.

Under crowded-band conditions, it may be found desirable to set the SELECTIVITY switch to the SHARP position for improved selectivity.

#### 5-4. USE OF THE "S" METER.

The "S" meter provides a visual means of determining whether or not the receiver is properly tuned, as well as an indication of the relative signal strength. The "S" meter circuit consists of a DC milliammeter connected in series

with the cathode lead of the first IF amplifier tube, the grid of which is controlled by AVC voltage. Since the cathode current of this tube varies with the strength of the incoming signal, the meter will indicate relative signal strength. The "S" meter is calibrated in "S" units from 1 to 9 and in decibels above S-9.

## SECTION VI SERVICE DATA

#### 6-1. CHASSIS REMOVAL.

To remove the chassis and panel assembly from the cabinet, first remove three screws from inside the cabinet, at the top of the front panel. These screws can be reached through the rear cabinet opening. Then remove five screws from the bottom of the cabinet. After these screws have been removed, slide the chassis forward and out of cabinet.

#### 6-2. TUBE AND DIAL LAMP REPLACEMENT.

Tubes may be replaced from the rear of the cabinet without removing the chassis. When replacing dial lamps, it is recommended that the chassis be removed from the cabinet. (Refer to paragraph 6-1.)

#### 6-3. DIAL RESTRINGING.

To restring the TUNING or BANDSPREAD dials, first remove the chassis from the cabinet (refer to paragraph 6-1). For stringing details, see figure 5.

#### 6-4. SERVICE AND OPERATING QUESTIONS.

For further information regarding operation or servicing of this equipment, contact the dealer from whom the unit was purchased. The Hallcrafters Company maintains an extensive system of Authorized Service Centers where any required service will be performed promptly and efficiently at no charge if the equipment is delivered to the service center within 90 days from date of purchase by the original buyer and the defect falls within

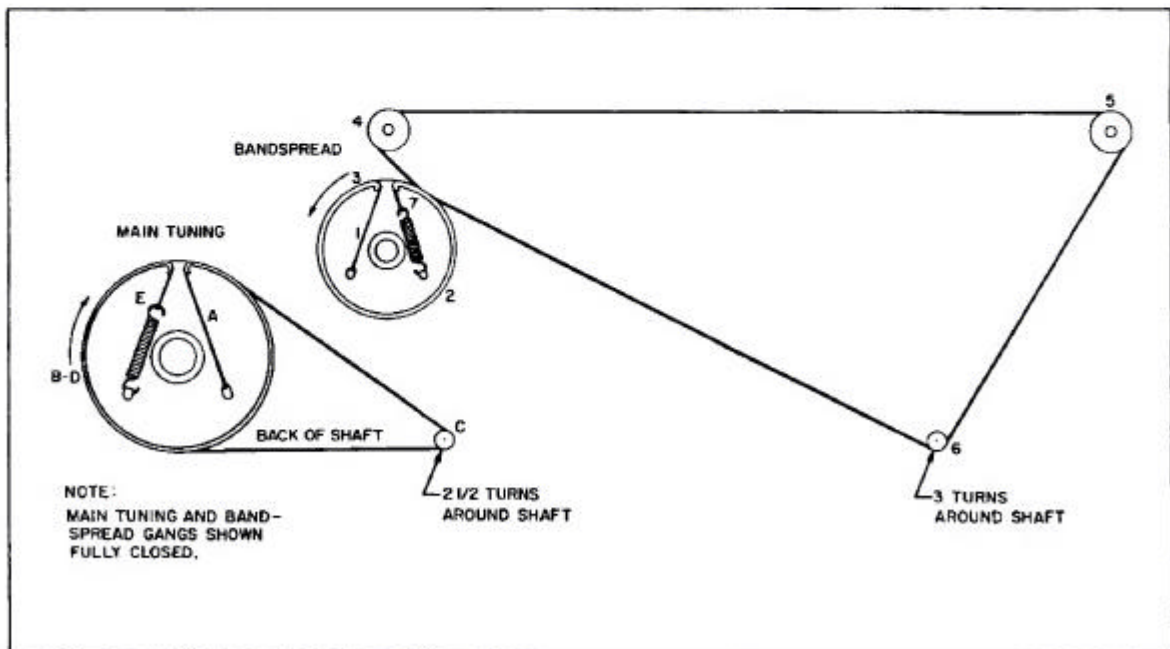

Figure 5. Dial Cord Restringing Diagram.

156-006153



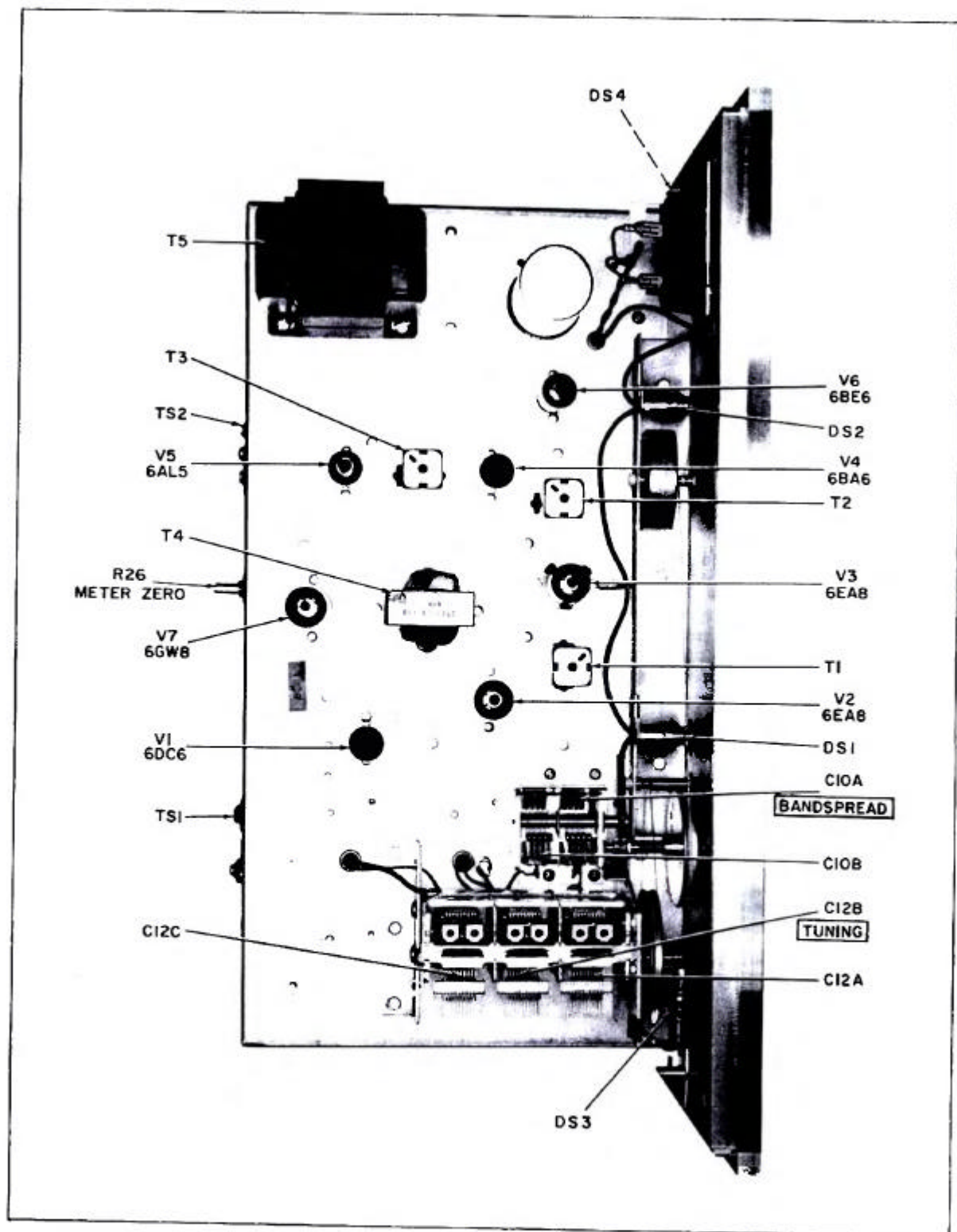

Figure 6. Top View of Receiver.

156-000124



the terms of the warranty. It is necessary to present the Bill of Sale in order to establish warranty status. After the expiration of the warranty, repairs will be made for a nominal charge. All Hallicrafters Authorized Service Centers display the sign shown at right. For the location of the one nearest you, consult your dealer or your local telephone directory.

Make no service shipments to the factory unless instructed to do so by letter, as The Hallicrafters Company will not accept responsibility for unauthorized shipments.

The Hallicrafters Company reserves the privilege of making revisions in current production of equipment and assumes no obligation to incorporate such revisions in earlier models.



## SECTION VII ALIGNMENT

This receiver has been carefully aligned at the factory by specially trained personnel using precision equipment. Alignment of the receiver should not be attempted until all other possible causes of faulty operation have been investigated. Alignment should not be required unless the receiver has been tampered with or component parts have been replaced in the RF or IF stages. Alignment should be performed only by persons familiar with communications receivers and experienced in their alignment.

### 7-1. EQUIPMENT REQUIRED.

1. Signal Generator covering 455 KC to 30 MC.
2. Vacuum Tube Voltmeter (VTVM).
3. Audio output power meter, set to 3-4 ohms.

### 7-2. INITIAL CONTROL SETTINGS.

BAND SELECTOR . . . As indicated in chart  
RF and AF GAIN . . . . . Maximum

XTAL PHASE . . . . . Center of range  
ANL . . . . . OFF  
FUNCTION . . . . . AM  
BANDSPREAD . . . . . Fully clockwise  
Other controls to be set as indicated by the alignment chart.

### 7-3. ALIGNMENT PROCEDURE.

The adjustments mentioned in the alignment chart may be located by referring to figures 6 and 7. Before proceeding with alignment perform the following:

1. Remove chassis from cabinet. (Refer to paragraph 6-1.)
2. The local oscillator is 1650 KC higher than the incoming signal on all bands.
3. Connect output meter to SPKR-GND terminals. Use just enough generator output to maintain a 500 milliwatt reading on the output meter.

### IF ALIGNMENT

STEP	SIGNAL GENERATOR COUPLING	SIGNAL GENERATOR FREQUENCY	RECEIVER CONTROL SETTINGS	ADJUST	REMARKS
1	Connect high side to pin 2 of V2 and low side to chassis.	1650 KC (approx.) unmodulated	BAND SELECTOR-1 SELECTIVITY - XTAL BROAD	Signal generator	Use enough gen. input to give a slight indication on the "S" meter. Adjust frequency of gen. for maximum deflection of "S" meter. The IF should be aligned to this crystal frequency.

IF ALIGNMENT (CONT.)

STEP	SIGNAL GENERATOR COUPLING	SIGNAL GENERATOR FREQUENCY	RECEIVER CONTROL SETTINGS	ADJUST	REMARKS
2	Same as step 1.	Crystal frequency. Modulate generator 30% with 400 cycles.	BAND SELECTOR-1 SELECTIVITY - NORMAL	T1, T2 & T3	Adjust top and bottom cores for maximum audio output.
3	Same as step 1.	Same as step 2 unmodulated.	BAND SELECTOR-1 SELECTIVITY - NORMAL FUNCTION-CW/SSB	L14	Remove knob from CW-USB-LSB control and adjust L14 shaft for zero beat. Replace knob with white indicator dot in center of CW line on panel.

RF, MIXER AND OSCILLATOR ALIGNMENT

All controls set as in initial control settings. Generator modulated 30% with 400 CPS.

STEP	SIGNAL GENERATOR COUPLING	SIGNAL GENERATOR FREQUENCY	RECEIVER CONTROL SETTINGS	ADJUST	REMARKS
1	Connect high side to A1, low side to GND. (A2 & GND tied together.)	1400 KC	BAND SELECTOR-1 TUNING - 1400 KC	C3 (Osc. trimmer) C23 (Mix. trimmer) C13 (ANT TRIM)	Adjust for maximum output.
2	Same as step 1.	600 KC	BAND SELECTOR-1 TUNING - 600 KC	L4 (Osc. coil) L12 (Mix. coil) C13 (ANT TRIM)	Adjust for maximum output.
3	Same as step 1.	4.0 MC	BAND SELECTOR-2 TUNING - 4.0 MC	C2 (Osc. trimmer) C22 (Mix. trimmer) C13 (ANT TRIM)	Adjust for maximum output.
4	Same as step 1.	1.8 MC	BAND SELECTOR-2 TUNING - 1.8 MC	L3 (Osc. coil) L13 (ANT TRIM)	Adjust for maximum output.
5	Same as step 1.	11 MC	BAND SELECTOR-3 TUNING - 11 MC	C1 (Osc. trimmer) C21 (Mix. trimmer) C13 (ANT TRIM)	Adjust for maximum output.
6	Same as step 1.	5.0 MC	BAND SELECTOR-3 TUNING - 5 MC	L2 (Osc. coil) L10 (Mix. coil) C13 (ANT TRIM)	Adjust for maximum output.
7	Same as step 1.	28 MC	BAND SELECTOR-4 TUNING - 28 MC	C6 (Osc. trimmer) C20 (Mix. trimmer) C13 (ANT TRIM)	Adjust for maximum output.
8	Same as step 1.	14 MC	BAND SELECTOR-4 TUNING - 14 MC	L1 (Osc. coil) L7 (Mix. coil) C13 (ANT TRIM)	Adjust for maximum output.



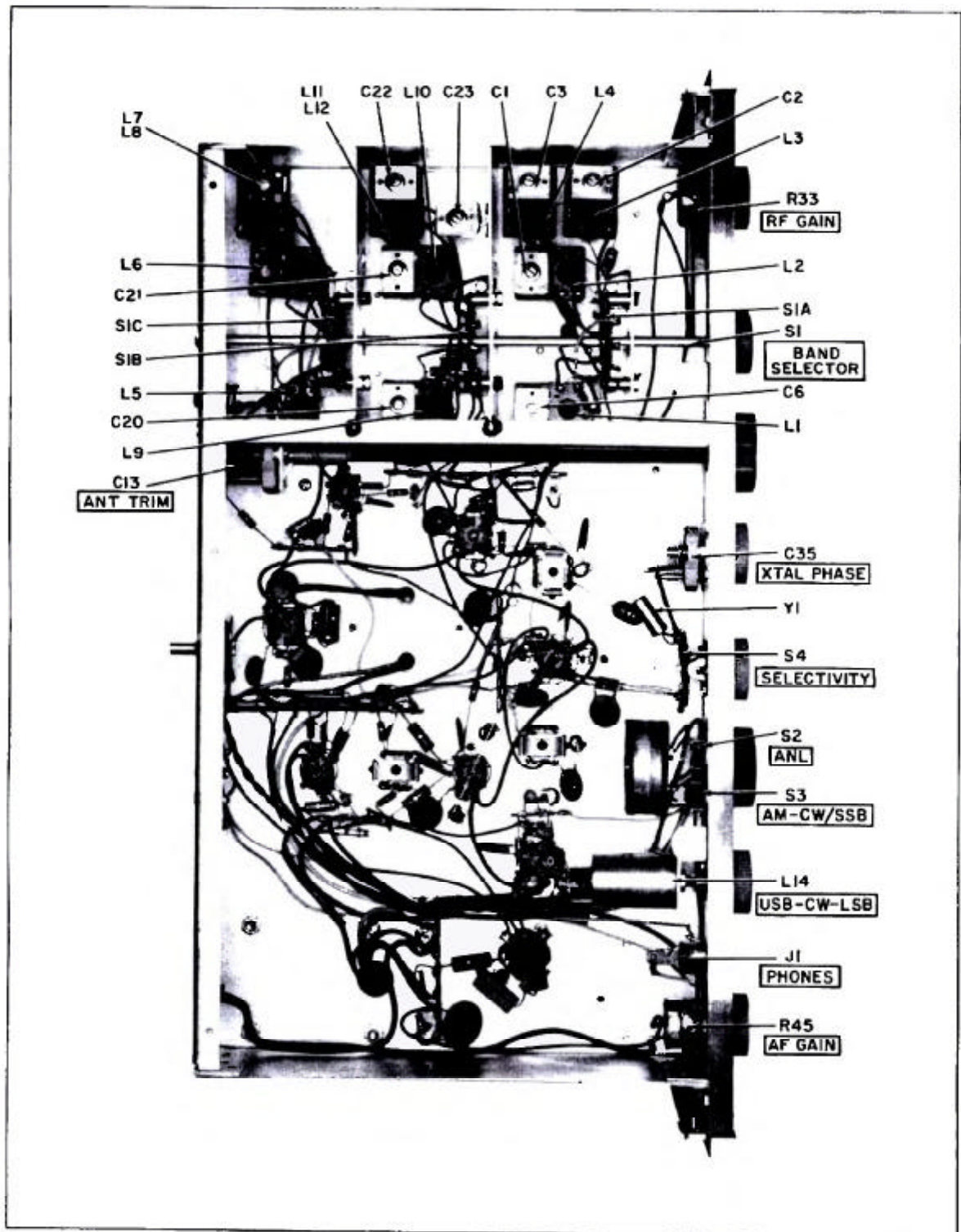

Figure 7. Bottom View of Receiver

156-006123

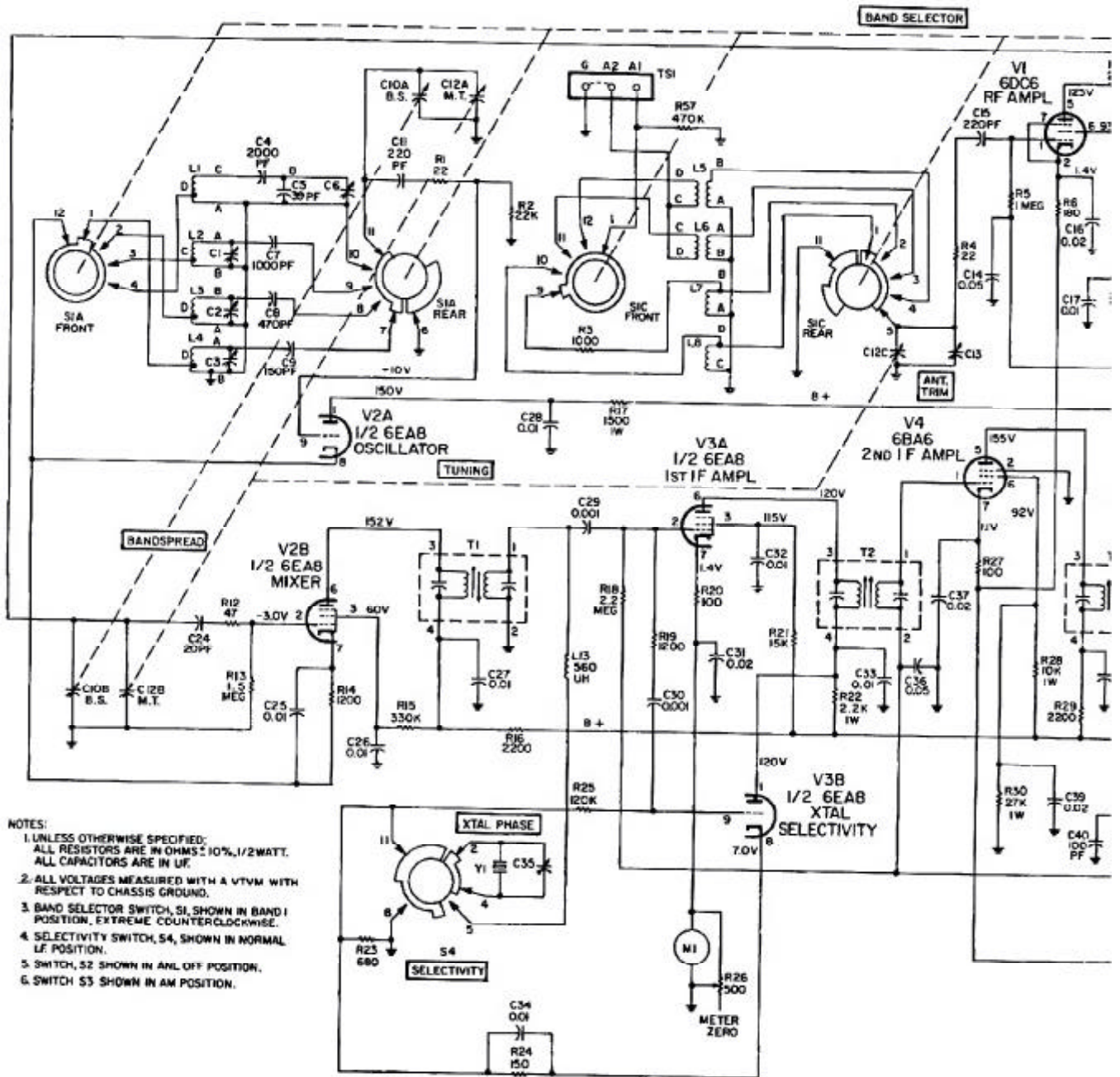
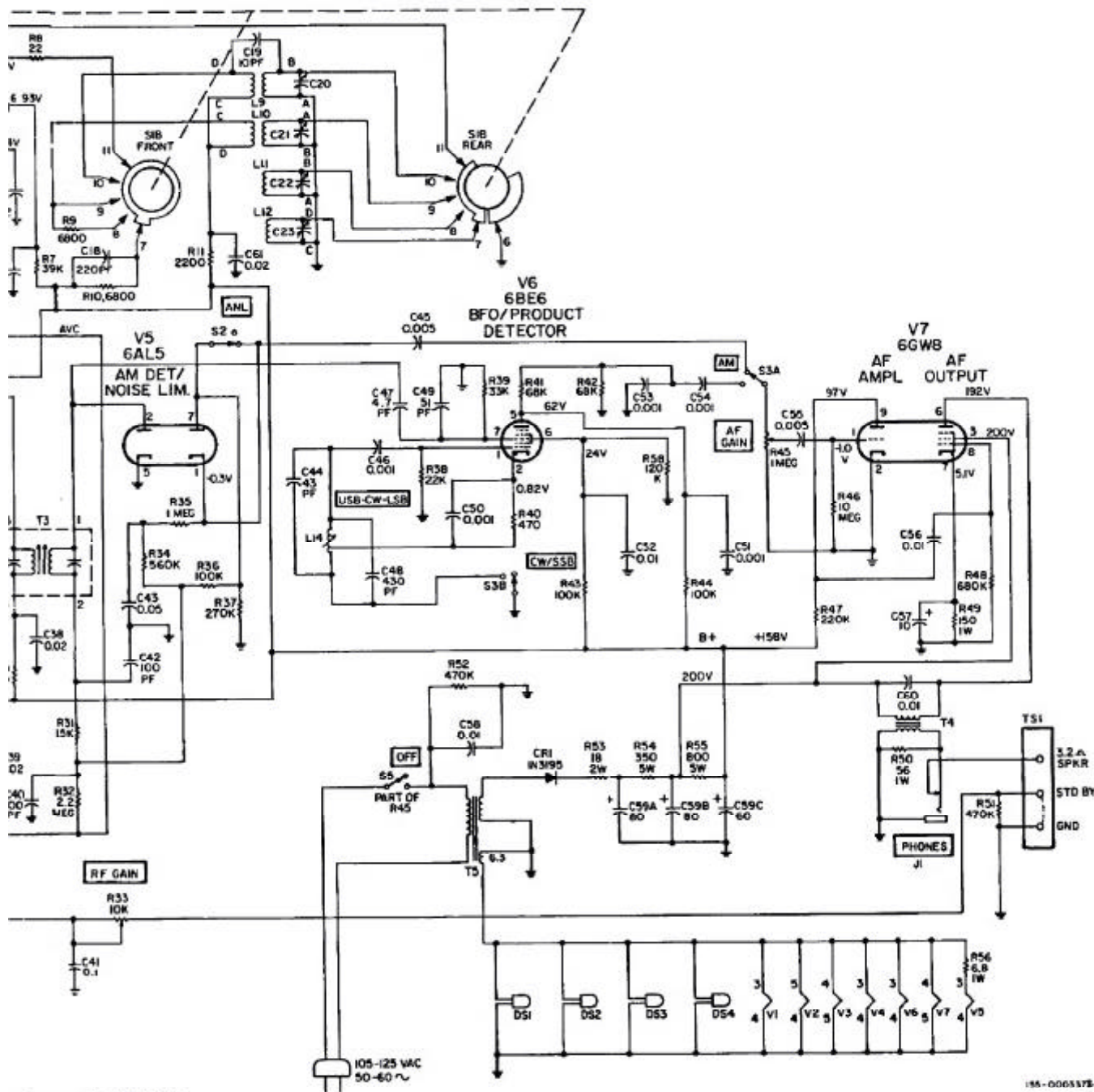

Figure 8. Schematic Diagram





c Diagram of Model SX-130.