

*Representant*  
*Baerbocher AG - Zürich*

OPERATING INSTRUCTIONS NO. EB 995

FM/AM SIGNAL GENERATOR

TYPE TF 995.

CONTENTS.

1. DESCRIPTION.

General.....1.1.  
 Design Details.....1.2.  
     (a) R.F. Circuits.  
     (b) Modulation Systems.  
     (c) Monitoring Arrangements.  
     (d) Power Pack.

2. OPERATION.

Installation.....2.1.  
 Connecting to a Receiver.....2.2.  
 Tuning the Signal Generator.....2.3.  
 Adjustment of the Output Level.....2.4.  
 Modulation.....2.5.  
 Synchronising Signal.....2.6.  
 Operational Summary.....2.7.

3. MAINTENANCE.

Valves.....3.1.  
 Deviation Calibration.....3.2.  
 Oscillator Crystal.....3.3.  
 Rectifier Crystal.....3.4.

Drawings: Functional Diagram TBI 20874  
 Complete Circuit TD 20337.

SCHEDULE OF PARTS SUPPLIED.

The complete equipment comprises the following items:-

1. One Instrument Type TF 995 complete with attached Mains lead, output cable and valves, etc. as under:-

- Valves: Seven: Type EF 91  
           One: Type EL91  
           One: Type 6C4 or L77  
           One: Type QS150/15  
           One: Type 5Z4G  
           One: Type EB91  
 Lamp:    One: Osram OS75 6.5V 0.3A.  
 Crystals: One: Type H.A. 333.33 kc/s Oscillator.  
           One: BTH Type CS/2/A Rectifier.

2. One: Terminating Unit Type TM 4308.
3. One: Plug - tip, ring and sleeve - ST and C 4006.
4. One: Instruction Book No. EB 995.

M.I.LTD.

1. DESCRIPTION.

1.1. General. The Signal Generator, which is a.c. mains operated, crystal standardised, and may be either frequency or amplitude modulated, has a frequency range of 13.5 Mc/s to 216 Mc/s in four bands and an output level range of 1µV to 100mV. Facilities are provided for both external and internal modulation, the latter at 1000 c/s to frequency deviations ranging from 25 kc/s to 600 kc/s - depending, in part, upon carrier frequency - and to amplitude modulation depths up to 50%.

A separate crystal-controlled oscillator provides fourteen checking points on each band and the beats may be heard either via the receiver under test or by head telephones plugged into the crystal oscillator circuit.

To facilitate tuning, a worm and wormwheel slow-motion drive is incorporated and the cursor of the tuning dial is adjustable so that it may be set to correspond exactly with the nearest crystal check point.

1.2. Design Details.

(a) R.F. Circuits. The r.f. oscillator itself is variable only over the fundamental frequency range of 4.5-9 Mc/s, the four output bands of 13.5-27 Mc/s, 27-54 Mc/s, 54-108 Mc/s and 108-216 Mc/s being obtained from a cascade of four ganged harmonic multipliers of X3, X2, X2 and X2 respectively, the outputs of which are selected by a frequency range switch. The r.f. output is applied to two resistive ladder-network attenuators in cascade, the first of these being in 20db stops (i.e., voltage decades) and the second in 2db steps, and thence via a screened output cable to a plug-on terminating unit having two outlets giving 1µV-100mV at a source impedance of 52Ω or 75Ω. The input to the attenuating system is monitored by a meter having ± 1 db calibration marks for fine adjustment.

The crystal calibrator - the crystal unit of which has a fundamental frequency of 333.33 kc/s - is coupled to the variable primary r.f. oscillator, the h.t. supply to the crystal controlled valve being switched on automatically when a telephone plug is inserted into the checking jack.

(b) Modulation System. Either external or internal a.f. modulation (f.m. or a.m.) may be applied, the internal source being a 1000 c/s valve oscillator. Frequency modulation is applied to the r.f. oscillator by a reactor valve fed from the a.f. source via a continuously variable potentiometer, cathode follower, and ganged attenuating system which maintains the deviation sensibly constant at all radio frequencies in every band. The normal deviation ranges on all carrier bands are 25 kc/s and 75 kc/s, but switching is provided which enables the deviation to be increased proportionally with increase in carrier frequency multiplication, the maximum deviation on the highest frequency band thus being  $75 \times 8 = 600$  kc/s.

Amplitude modulation, to a continuously variable depth extending to 50% in the case of the internal 1000 c/s source, is applied to whichever of the harmonic multipliers is functioning as output stage, this method

M.I.LTD.

helping to reduce the spurious frequency modulation often encountered when modulating the r.f. oscillator directly.

(c) Monitoring Arrangements. A moving coil microammeter on the front panel, used in conjunction with a crystal rectifier, continuously monitors the r.f. input to the attenuators when a spring-loaded key-switch is in the normal position; the two alternative positions are for reading f.m. deviation and a.m. depth respectively, the former by the measurement of the modulating voltage injected into the reactor valve and the latter by similarly checking the input to whichever multiplier is operating as output stage.

(d) Power Pack. A full wave valve rectifier provides all d.c. h.t. requirements; in the case of the reactor and r.f. oscillator valves the h.t. is neon stabilised. The primary of the transformer is tapped to allow for operation from 100V - 150V or 200V - 250V, and adequate r.f. filtering is introduced into the a.c. input circuit.

## 2. OPERATION.

2.1. Installation. The instrument is normally despatched ready for operation from 230V 40-100 c/s supplies unless otherwise specified. It can also be adjusted for operation from other voltages between 100-150V or 200V - 250V. Should it be necessary to alter the transformer tapplings, remove the panel from the case to gain access to the mains transformer, which forms part of the power pack and is attached to the bottom of the case. If necessary, the main panel assembly can be separated from the power pack by disengaging the 6-way plug-and-socket connection on the latter. If the operating voltage is between 200V and 250V the only action necessary is the changing of the fly-leads on the front tag panel. If, however, the supply voltage is between 100V - 150V, the two leads strapping tags 2 and 3 (on the small tag panel at the rear of the transformer) should be unsoldered and connected so that tags 1 and 2 are common, and tags 3 and 4 are common. The fly leads should then be removed from the larger tag panel, the panel removed by unscrewing the one fixing screw, turned over and replaced. The fly leads should now be connected as required in accordance with the 100V-150V markings on the now reversed - front tag panel.

2.2. Connecting to a Receiver. The output cable, which is permanently attached to the Signal Generator, is terminated in a coaxial socket and when not in use normally housed in the right-hand handle recess.

For general test use, the output cable should be connected to the Input socket of the TERMINATING UNIT supplied with the instrument. The 52 $\Omega$  or 75 $\Omega$  OUTlets of the terminating unit may then be directly connected to the aerial input of receivers with 52 $\Omega$  or 70/80 $\Omega$  input circuits i.e. receivers designed to operate from sources having impedances of this order; the e.m.f. developed by the Signal Generator itself being in series with the internal 52 $\Omega$  or 75 $\Omega$  source impedance.

Where the receiver under test is in such a condition that a large input is required to obtain any preliminary response, the output cable may be connected directly to the receiver. The output impedance is then 75 $\Omega$

M.I.LTD.

and the output voltage is doubled, i.e. increased by 6db relative to that indicated on the panel meter and attenuators.

**2.3. Tuning the Signal Generator.** Select the appropriate frequency range by means of the RANGE switch and rotate the TUNE control until the required frequency marking on the dial is opposite the cursor line.

Where the highest frequency accuracy is required, plug a pair of high resistance phones into the CRYSTAL CHECK jack and check the dial calibration against the nearest harmonic beats available. Any slight discrepancy at the check points should be allowed for by adjustment of the milled boss in the centre of the dial to bring the cursor exactly in line with the calibration mark at the frequency to which the Signal Generator is tuned.

**2.4. Adjustment of the Output Level.** The r.f. output of the instrument is monitored by the panel meter and controlled by two attenuators, marked OUTPUT VOLTAGE and MULTIPLY BY. Having tuned the Signal Generator to the required frequency, bring the meter to the SET R.F. mark by means of the SET CARRIER control. The output level at the 52Ω or 75Ω OUTlet on the TERMINATING UNIT is then equal to the setting of the OUTPUT VOLTAGE attenuator multiplied by the setting of the MULTIPLY BY attenuator.

The various attenuator settings are also engraved in red to indicate the output level in db relative to 1μV and, since adjustment of the attenuators gives a minimum output level increment of 2db, the panel meter is also scaled with +ldb and -ldb marks above and below the SET R.F. mark. Where an output level equivalent to an odd number of decibels relative to 1μV is required, adjust the attenuators to the nearest even number, and by means of the SET CARRIER control adjust the panel meter to indicate plus or minus ldb as required.

The output voltage levels indicated by the attenuator settings, and which refer to the 52Ω or 75Ω outlets of the TERMINATING UNIT, are only correct when the meter reading is maintained at the SET R.F. mark.

**2.5. Modulation.** The Signal Generator can be operated with the carrier unmodulated, frequency modulated or amplitude modulated from either an internal or external source, the choice of modulation being made on the MOD SELECTOR switch. For unmodulated operation the switch should, of course, be set to C.W.

(a) Frequency Modulation. To frequency modulate the carrier at 1000 c/s by means of the internal a.f. oscillator, turn the MOD SELECTOR to INT MOD - F.M. and set to the required deviation, as indicated in kc/s on the appropriate scale of the meter when the METER READS key switch is temporarily held to F.M., by adjusting the SET MOD control; on centring the key the deviation becomes that previously indicated by the meter and the latter is returned to its normal r.f. monitoring function.

The maximum deviation indicated by the meter is determined by the settings selected for the two controls, DEVIATION RANGE and DEVIATION, NORMAL - HIGH. With the latter at NORMAL the maximum deviation obtainable,

M.I.LTD.

and thus the appropriate meter scale, is determined by the selection of either 25 kc/s or 75 kc/s on the DEVIATION RANGE switch. With the DEVIATION, NORMAL - HIGH switch set to HIGH the maximum deviation as indicated by the panel meter and DEVIATION RANGE switch is multiplied as follows: on the 27-54 Mc/s band, X2; on the 54-108 Mc/s band, X4 and on the 108-216 Mc/s band, X8.

To apply external frequency modulation within the range 50 c/s to 15 kc/s, switch to EXT MOD - F.M. and inject the external source between the Earth and EXT MOD terminals. The deviation may be set and monitored as in the case of internal frequency modulation. An input of the order of 15-20V r.m.s. is required for full deviation with the DEVIATION RANGE switch set to either 25 kc/s or 75 kc/s and the DEVIATION, NORMAL - HIGH switch set to NORMAL.

(b) Amplitude Modulation. To amplitude modulate the carrier at 1000 c/s by means of the internal a.f. oscillator set the MOD SELECTOR switch to INT MOD - A.M. and, by means of the SET MOD control, set to the required depth on the top scale of the meter with the METER READS key held in the A.M. position. As in the case of frequency modulation the modulation becomes that previously indicated by the meter when the METER READS key is returned to its central position.

To apply external amplitude modulation within the range 50 c/s to 10 kc/s switch to EXT MOD - A.M. and apply the external source between the Earth and EXT MOD terminals; the modulation depth being set and monitored as in the case of internal amplitude modulation. An input of the order of 30V r.m.s. is required for 30% modulation.

2.6. Synchronising Signal. If a synchronising signal is required from the internal 1000 c/s audio oscillator, or if the audio tone is required for external testing purposes, it may be taken from between the SYNC and Earth terminals when the MOD SELECTOR switch is set to either INT MOD - F.M. or INT MOD - A.M. The level is of the order of 100V r.m.s. at a source impedance of approximately 250  $\Omega$ .

2.7. Operational Summary. The following is a brief summary of the foregoing operating instructions, the figures in brackets referring to the sections in which the various points are more fully discussed.

Supply: Check that the mains transformer is correctly adjusted for the mains voltage (2.1).

Connections: Normally couple the output cable to the TERMINATING UNIT and take the output from the latter's 52 $\Omega$  or 75 $\Omega$  calibrated OUTlet socket (2.2).

To produce r.f. signals: Switch on the SUPPLY, set to the appropriate frequency range and adjust the TUNE control to indicate the required frequency (2.3).

Output Level: Switch to C.W. and bring the meter to the SET R.F. mark by means of the SET CARRIER control. At the SET R.F. mark the e.m.f. at the 52 $\Omega$  or 75 $\Omega$  OUTlet is as shown by the product of the attenuator engravings

M.I.LTD.

and is correspondingly more or less at the + ldb and -ldb marks (2.4).

Modulation: To frequency modulate the carrier at 1000 c/s switch to INT MOD - F.M. Select the required deviation range by means of the DEVIATION RANGE and DEVIATION, NORMAL - HIGH switches; hold the METER READS key temporarily to F.M. and adjust the SET MOD control to produce the required deviation. To apply external frequency modulation, switch to EXT MOD - F.M., apply external source between EXT MOD and Earth terminals and set deviation as before. (2.5.a).

To amplitude modulate the carrier at 1000 c/s switch to INT MOD - A.M., hold the METER READS key temporarily to A.M. and adjust the SET MOD control to produce the required depth. To apply external amplitude modulation, switch to EXT MOD - A.M., apply external source between EXT MOD and Earth terminals and set modulation depth as before (2.5.b).

Synchronising Signal: An audio test tone is available between SYNC and Earth terminals when the MOD SELECTOR switch is set to either INT MOD - F.M. or INT MOD - A.M. (2.6).

### 3. MAINTENANCE.

3.1. The valves, which are listed on Page One under Schedule of Parts Supplied, are accessible after removing the instrument from its case; all r.f. valves are within an inner screening compartment which may be removed after slackening the three screws at its rear.

Replacement of the r.f. oscillator or reactor valves may affect the deviation calibration to some extent unless the valves are specially selected.

3.2. The deviation calibration may be checked, and restored by the adjustment of an internal preset control, either by comparison with a Deviation Meter (such as Marconi Instruments Type TF 791B) or by the "disappearing carrier" method described below. In either case, the calibration may be restored by adjustment of the preset resistor marked R82 on the circuit diagram and mounted on the sub-chassis behind the meter.

The second method of checking referred to above depends upon the fact that the carrier - as opposed, of course, to the side-bands - disappears when the modulation index  $\mu$  (the ratio of the frequency deviation  $\delta F$  to the modulation frequency  $f$ ) has values of 2.4048, 5.5201, 8.6537, 11.7915, etc. Therefore, the deviation  $\delta F = \mu f$ ; for example, if the applied modulation has a frequency of 10 kc/s and the deviation is progressively increased until the carrier disappears, the deviation must be  $2.4048 \times 10 = 24$  kc/s and, again,  $5.5201 \times 10 = 55.2$  kc/s.

To determine these points, apply the output of the Signal Generator to a narrow band (communication) a.m. Receiver and tune the latter to the unmodulated output frequency of the Signal Generator. Set the beat oscillator of the receiver to give an audio note, then frequency-modulate the signal at a fairly high frequency outside the pass band of the a.m. receiver, such as 10 kc/s, starting from zero deviation and increasing the deviation until the beat with the carrier disappears. At this point the actual deviation

M.I.LTD.

can be calculated as described above and the preset control within the Signal Generator set to produce this reading on the meter when the METER READS key is temporarily held to F.M.

N.B. The deviation must be determined with the key central, not in the F.M. position.

3.3. The oscillator crystal (333.33 kc/s) is of the plug-in type, and is accessible after removing the cover of the r.f. box.

3.4. The rectifier crystal is accessible after removing the cover of the attenuator. The crystal is B.T.H. type CS/2/A, and is inserted in clips.

The static conditions are of the following orders:-

a.c.h.t.	= 250-0-250
a.c.l.t.	= 6.3V
d.c.h.t.(1)	= 250V
d.c.h.t.(2)	= 150V

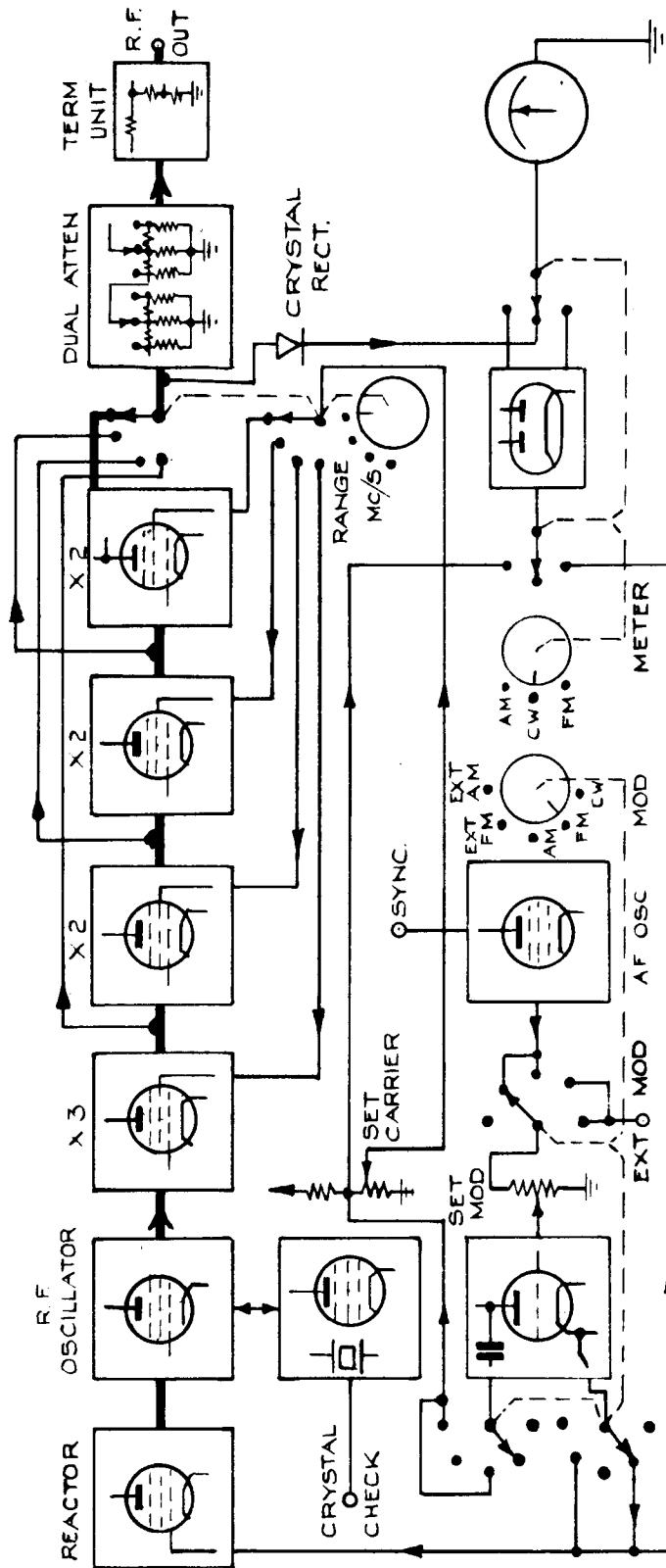

MARCONI INSTRUMENTS LTD				TITLE	FUNCTIONAL DIAGRAM OF FM/AM SIGNAL GENERATOR		
DRN	K.H.N	CHKD	APPVD	STOCK LIST	TF.995	DRG. No	TBI.20874
DATE	3-7-50						