

AGAF e.V. DATV-Boards

developed at the

Bergische University of Wuppertal

supported by

AGAF e.V. and DARC e.V.

Instructions for starting-up

Autumn 2004

Version 1



1. Introduction and basic concept

The AGAF e. V. DATV boards are delivered as a kit. They are intended to enable an amateur to get operational quickly on DATV. Just a few things need to be done to get started. The boards use the European standard dimensions of 160 mm x 100 mm and fit into a 19" rack. They can also be mounted using standoffs from a chassis.

The boards provide the basic equipment necessary for a DATV station. The RF signal output, in the 70 cm band (434 MHz), is digitally modulated with compressed vision and sound. For experimental purposes it is possible to choose several digital modulation schemes and data rates. All modulation schemes are available except OFDM (DVB-T). Currently QPSK and GMSK are most appropriate for amateur use.

The 70 cm output can be fed to a power amplifier and transmitted directly in that band provided that the total RF bandwidth is within agreed limits. Up-converters can be used to enable transmission in the GHz bands.

The **QPSK** (Quadrature Phase Shift Keying) modulation is in accordance with DVB-S standards. This enables inexpensive free to air DVB-S set top boxes to be used for reception. They can be tuned directly to frequencies in the 23 cm band and then carry out error correction and MPEG decoding. DVB-S transmissions on other amateur bands may be received using a frequency converter in front of the set top box.

A significant disadvantage of QPSK modulation for amateur use is the need for linear amplification. Additional amplitude modulation introduced by amplifiers having inadequate linearity causes broadening of the signal spectrum which can cause interference to services on adjacent channels. This problem may be reduced by derating amplifiers to operate well below their maximum output.

As digital satellite set top boxes have no echo-equalisers, multipath propagation on terrestrial paths could, in theory, cause problems. Intensive field tests by DB0KO and test transmissions during HAM-Radio in hilly terrain have however shown that this problem can be overcome in most cases by using antennas with high directivity.

GMSK (Gaussian Minimum Shift Keying) performs very well. As it uses a constant modulation envelope the spectrum does not become broader with non-linear amplification (similar to FM). This enables non-linear amplifiers as are used for FM ATV to be employed for DATV. The disadvantage of GMSK is the need for a special receiver. Such a receiver has been developed and is working as a prototype. The first DX field tests (> 100 km) have clearly shown the advantages of GMSK.

2. Getting started

The kit as delivered consists of two boards, the MPEG-encoder and the exciter. It is recommended that the user read all instructions before connecting any signals or power.

2.1 DATV-MPEG Encoder Board (Fig. 1)

analogue signal inputs:

- CVBS: PAL / NTSC
- Y / C
- audio right
- audio left

digital signal outputs

- MPEG transport stream: connector JP1 (PECL)
- MPEG transport stream: connector JP2 (PECL)

supply voltage: 12 V DC (ca. 11 V to 14 V), stabilized and decoupled from impulse noise

- + 12 V at JP1
- GND at JP2

Wires may be soldered to the delivered connectors; a built-in protection circuit prevents the board from damage due to accidentally applied inverse voltage polarity.

- lower operating voltages are derived from 12 V by voltage regulators and are connected to the related circuit parts via jumpers.
 - + 5 V (linear regulator): JP4
 - + 1,8 V (switch mode) : JP3
 - + 3,3 V (switch mode) : JP10

The current values given in the diagram are standard values; the actual currents depend on the operating mode chosen. As delivered these jumpers have standard settings.

Jumper settings:

The choice of the video input signal (PAL or NTSC, CVBS or Y/C) and the presets of the Bit rate of the elementary stream and of the Bit rate of the transport stream are set by jumpers.

These jumpers might be replaced by suitable plugs, connected to toggle switches by twisted lines thus enabling the adjustments from the front panel of a cabinet.

The given positions of the jumpers are valid for the software version 1, which is loaded to the board when delivered.

The positions of the jumpers when delivered are marked with (standard). For operation a jumper must be set to position 3 of the connector JP6.

The choice of the analogue video signal and the adjustment of the Bit rate of the elementary stream

Jumper connector JP5 X = jumper in position 0 = jumper not in position

| <u>position</u> | <u>jumper</u> | <u>function</u> | <u>remarks</u> |
|-----------------|---------------|-----------------|----------------|
| 8 | 0 | NTSC | |
| 8 | X | PAL | (standard) |
| 7 | 0 | Y/C | |
| 7 | X | CVBS | |

Data rate of the elementary stream

| | | | |
|---|---|------------|------------|
| 6 | 0 | 1,5 MBit/s | |
| 5 | 0 | | |
| 6 | 0 | 3,0 MBit/s | |
| 5 | X | | |
| 6 | X | 4,5 MBit/s | |
| 5 | 0 | | |
| 6 | X | 6,0 MBit/s | (standard) |
| 5 | X | | |

Adjustment of the data rate of the transport stream

Jumper connector JP9: one jumper set only

| Position: | 1 | 2 | 3 | 4 | 5 | 6 |
|---------------------------------------|----|------|------------|-------|--------|-------------------------------------|
| Data rate of transport stream: MBit/s | 27 | 13,5 | 6,75 | 3,375 | 1,6875 | optional external Clock (right pin) |
| | | | (standard) | | | |

The data rate of the transport stream has to be chosen to be higher than the data rate of the elementary stream; the difference is filled with zero packets in the transport stream.

Having switched on the supply voltage the MPEG-encoder IC MB86391 is programmed by the micro controller MB90F591 according to the jumper settings (power on initialisation). With the software version 1 this procedure lasts about 10 seconds, the red LED1 flashes 10 times and then goes out. Depending on the choice of the analogue input signal the green LED2 (Y/C) or the green LED3 (PAL/NTSC) are switched-on permanently. This indicates that the MPEG encoder is ready for operation.

With software version 1 the start procedure may fail occasionally; in this case the red LED1 lights up permanently.

This problem can be solved by restarting the initialisation procedure by switching off the 12 V power supply and on again after a few seconds.

After every change of the jumper settings a new initialisation must be initiated by switching the 12 V supply off and on again.

2.2 DATV – Exciter (Fig. 2)

signal input: MPEG transport stream via connector J2 (PECL)

signal outputs: SMA - connector

- RF out 434 MHz
- IF out 44 MHz
- LO out 478 MHz

The transmission of the MPEG transport stream from the MPEG encoder (e.g. from connector J1) to the exciter (connector J2) is carried out via the flat cable supplied.

Pin 1 (black square) of the MPEG encoder output connector corresponds to pin one of the exciter input connector (black square).

The connection of the flat cable has to be made so that the coloured line on both sides is connected to pin 1.

Warning: the transport stream input of the exciter is voltage-sensitive, higher voltages than 3,3 V could destroy the FPGA; therefore please do not connect standard TTL signals and PC outputs.
The amplifier connected to the RF output must not oscillate; the output amplifier of the exciter could be destroyed.

Supply voltage: 12 V DC (about 11 V to 14 V), stabilized and decoupled from impulse noise

- + 12 V at JP1
- GND at JP2

- wires may be soldered to the delivered connectors; a built-in protection circuit prevents the board from damage due to accidentally applied inverse voltage polarity.
- lower supply voltages will be derived from 12 V by voltage regulators and are connected to the respective circuit parts via jumpers.

- + 7,5 V (linear regulator) : JP3
- + 3,3 V (switch mode) : JP4
- + 1,5 V (switch mode) : JP5

The current values given in the diagram are standard values, the actual current depend on the operating mode chosen depend each on the operating state adjusted. As delivered these jumpers have standard settings.

Jumper settings:

The choice of the digital modulation scheme, the data rate and the symbol rate, respectively, as well as the FEC (forward error correction) is set by jumpers or by respectively connected switches on the front panel.

The positions of the jumpers apply to the software version 1 loaded with delivery.

For the adjustment of the various transmission modes connector JP7 is used only

X = jumper in position; 0 = jumper not in position; (standard) marks the settings with delivery.

| Position | jumper | function |
|----------|--------|----------------------------------------------|
| 1 | 0 | GMSK 2 MBit/s, QPSK 4,167 MSymb/s (standard) |
| 1 | X | GMSK 5 MBit/s, QPSK 7,5 MSymb/s |
| 2 | 0 | GMSK |
| 2 | X | QPSK (standard) |

| | Forward Error Correction | | | | | |
|---|--------------------------|-----|-----|-----|-----|-----|
| | 1/2 | 2/3 | 3/4 | 5/6 | 6/7 | 7/8 |
| 3 | 0 | X | 0 | 0 | X | 0 |
| 4 | 0 | 0 | X | 0 | 0 | X |
| 5 | 0 | 0 | 0 | X | X | X |

The data rate of the exciter must always be set to be higher than the data rate of the transport stream of the MPEG encoder.

In the FPGA the MPEG transport stream first is split up again and zero packets are inserted according to the higher transmission data rate and the FEC chosen.

The digital modulation, with software version 1 both GMSK and QPSK, are digitally generated at 44 MHz with a 125 MHz clock and 14 Bit resolution.

The D/A-converter delivers the analogue IF signal as two push-pull currents, which are lead to a transformer in the IF/RF processing unit (fig. 3). The RF-power adjust potentiometer controls the analogue output of the D/A converter.

With delivery the RF output on 434 MHz is adjusted to about 0 dBm in QPSK - and about 10 dBm in GMSK-mode.

The IF-signal and the LO-signal are both available in an attenuated form for experiments.

The optional connectors, shaded parts in Fig.2, are used for additional features of further developments.

2.3 Explanation of the settings of the data rates of the MPEG encoder and the exciter as delivered (standard settings):

The data rate of the elementary stream defines the maximum possible image quality at the receiver. The image quality with 6,0 MBit/s is approximately equal to the image quality of digital broadcast television. The data rate of the transport stream is set to 6,75 MBit/s; the difference to the data rate of the elementary stream is increased by the data rate of the mono and the stereo sound signal, respectively and by zero packets. The exciter accepts the transport stream of the MPEG encoder in an asynchronous mode, adds the FEC (standard 7/8) and inserts more zero packets; this results in a total data rate of 8,334 MBit/s. In QPSK 2 bits form one symbol; thus the symbol rate is 4,167 MSymb/s (in GMSK one Bit is one symbol; accordingly in this case symbol- and bit rate are equal).

3. Adjustments of a DVB-S Set-Top Box for standard operation, as delivered

The DVB-S Set-Top Box receives the QPSK modulated DATV-Signal directly in 23 cm band between 1240 MHz and 1300 MHz on the frequencies agreed for ATV or the DATV-signal is converted from another amateur bands to 23 cm.

Frequency programming of the DVB-S set top box:

Frequency in the 23 cm band + 10600 MHz (LO frequency of LNB)

(for example: 1255 MHz + 10600 MHz = 11855 MHz (Frequency to be programmed))

Symbol rate: 4167
Video-PID : 33 (decimal)
Audio-PID : 49 (decimal)

4. Further developments

4.1 70cm/23cm Up-Converter

- The development is finished
- 50 Boards with SMD RLC components, semi-conductors and mixer have been produced, for information about delivery contact AGAF e.V.
- common ordering of Helical-filters, tinfoil boxes and SMA connectors: look at DATV forum of DD1KU
- circuit and print information is available at www.datv-agaf.de

4.2 70cm/13cm up-converter

- The development is finished, prototype works
- low volume production of boards is in preparation
- circuit and print information is available at www.datv-agaf.de

4.3 70 cm GMSK-receiver consisting of

- An RF/IF board (2.5 MHz and 6 MHz IF-bandwidth)
- A board for digital GMSK decoding and re-modulation in DVB-S on 1100 MHz to connect o a DVB-S Set-Top Box and a parallel, digital MPEG transport stream output to connect a MPEG decoder
- A prototype is working, DATV DX experiments over more than 100 km have been carried out
- low volume production is in preparation

4.4 MPEG Decoder board

- A first prototype is finished, but has to be tested

4.5 70cm front-end for DVB-S Set-Top Box

- For reception of narrow band DATV QPSK-signals on 70 cm
- A prototype is working
- low volume production is in preparation

4.6 23cm/70cm Down-Converter

- The first prototype is ready for test

4.7 Hard disk recorder for connection to the DATV-Exciter

- standard PC hard disk connected to optional HDD Interface
- controlled by PC user interface via PC parallel port
- recording and play back (transmission from hard disk) is working
- further developments for user-friendly operation are in progress.

4.8 Byte-Blaster II

- Hardware for downloading the system software from the PC to the DATV-exciter
- The prototype is working
- low volume production in preparation

4.9 Software Version 2 for MPEG-Encoder

- initialisation phase shorter than 5 seconds
- Watchdog, which starts the initialisation again in case of a malfunction in the start-up phase or in case of a malfunction during operation due to external distortions
- adjustments of the elementary and the transport stream data rates in 0,5 MBit/s) steps
- automatic detection and connection of the analogue input which has a valid video signal
- transmission of the software version 2 via internet and downloading to the MPEG-encoder has been achieved.
- Software Version 2 will be downloadable from www.datv-agaf.de
- description with new settings of the jumper positions is in preparation

4.10 Software Version 2 for DATV-Exciter

- this software contains more tables, so that practically all Set-Top boxes could be used for QPSK-reception.
- the software version 2 has also been sent via the internet and has been downloaded with the byte-blaster II to the exciter board.
- download of software version 2 will be possible from www.datv-agaf.de
- the description is in preparation

4.11 Software for reduced transmission bandwidth

Software for a lower data rate is in development, in particular aiming at RF-bandwidths of 1 MHz and 2 MHz for QPSK to be used on 70 cm.

4.12 OFDM Exciter for DVB-T

An OFDM exciter has been built and tested successfully in field tests (see www.datv-agaf.de)
A cheaper version for DATV will be developed.

Notes:

- the finishing of the projects strongly depends on the available time of the participating amateurs and other assistants.
- the realization of a low volume production depends also on the financing

5. Development work and OM involved

The development of the DATV kit, the production, adjustments and shipping as well as further projects mentioned in 4., was and will be carried out by students and scientific assistants of the Department of Communications Technology at the University of Wuppertal and some amateurs, which are ideally connected to the Department and the DATV-project.

These are Hans, DJ8VR (sk); Rudolf, DJ3DY; Willi, DC5QC; Klaus, DL4KCK; Heinz, DC6MR; Stephan, DM1SM; Adnan El-Bardawil (still unlis); Uwe, DJ8DW

The DATV kit has been developed and produced under an official cooperation agreement between the Bergische University of Wuppertal and the AGAF e.V. with ideal support of the DARC e.V.

6. Help with problems

Thanks to Uli, DD1KU for arranging a DATV forum on the internet www.dd1ku.de/DATV/Forum/datv/forum.html for questions and exchange of experiences, this forum is also linked to www.datv-agaf.de

Ordering information from the AGAF e.V.
Heinz dc6mr@t-online.de

Answers to special technical questions:
Klaus dl4kck@t-online.de and Uwe krausue@uni-wuppertal.de

Thanks for the invaluable help by Ian Waters, G3KKD in refining this translation into good English.

Autumn 2004

Uwe E. Kraus, DJ8DW / PA3ACY

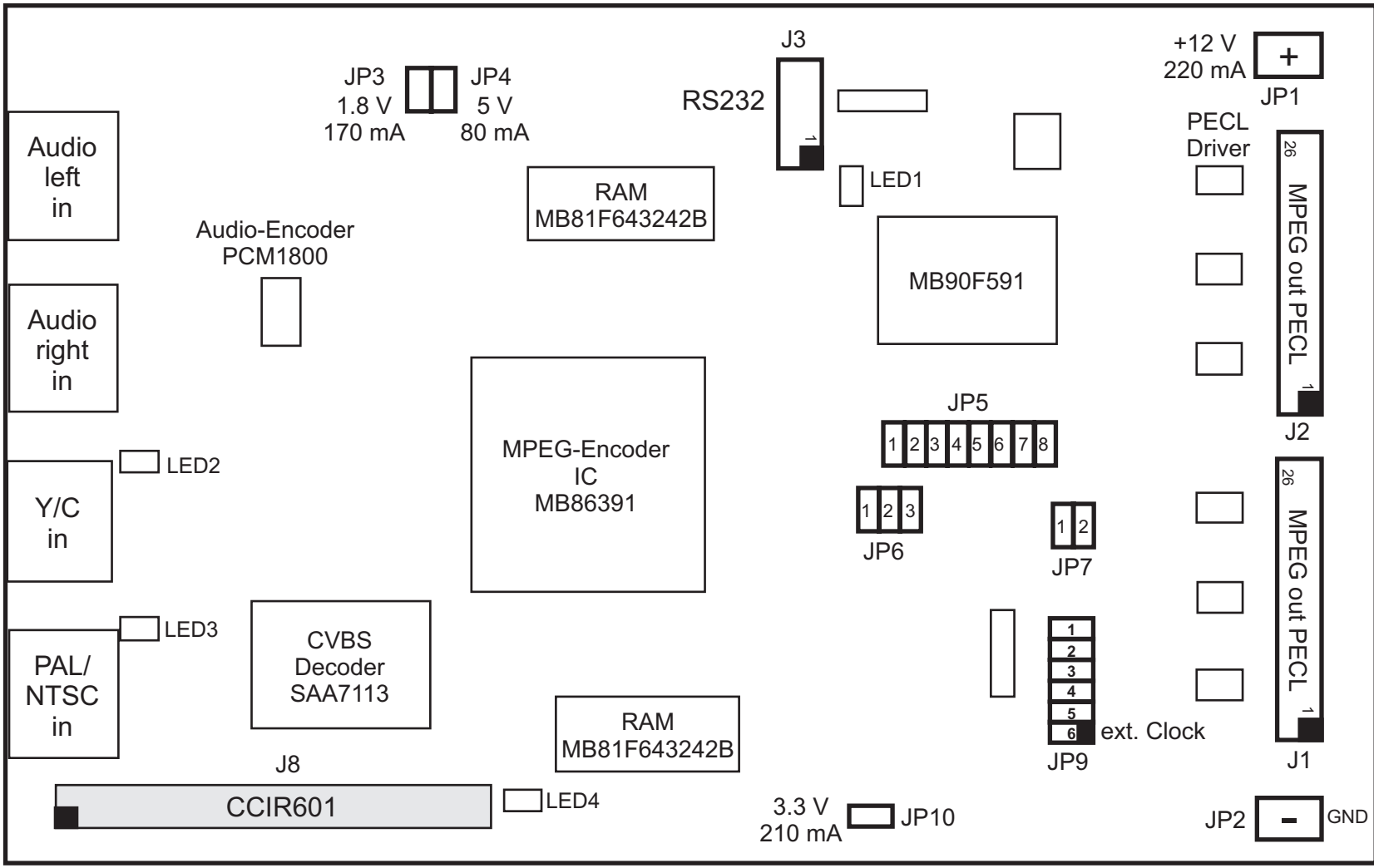

 optional

AGAF e.V.
Fig. 1

DATV-MPEG Encoder Board

Top View



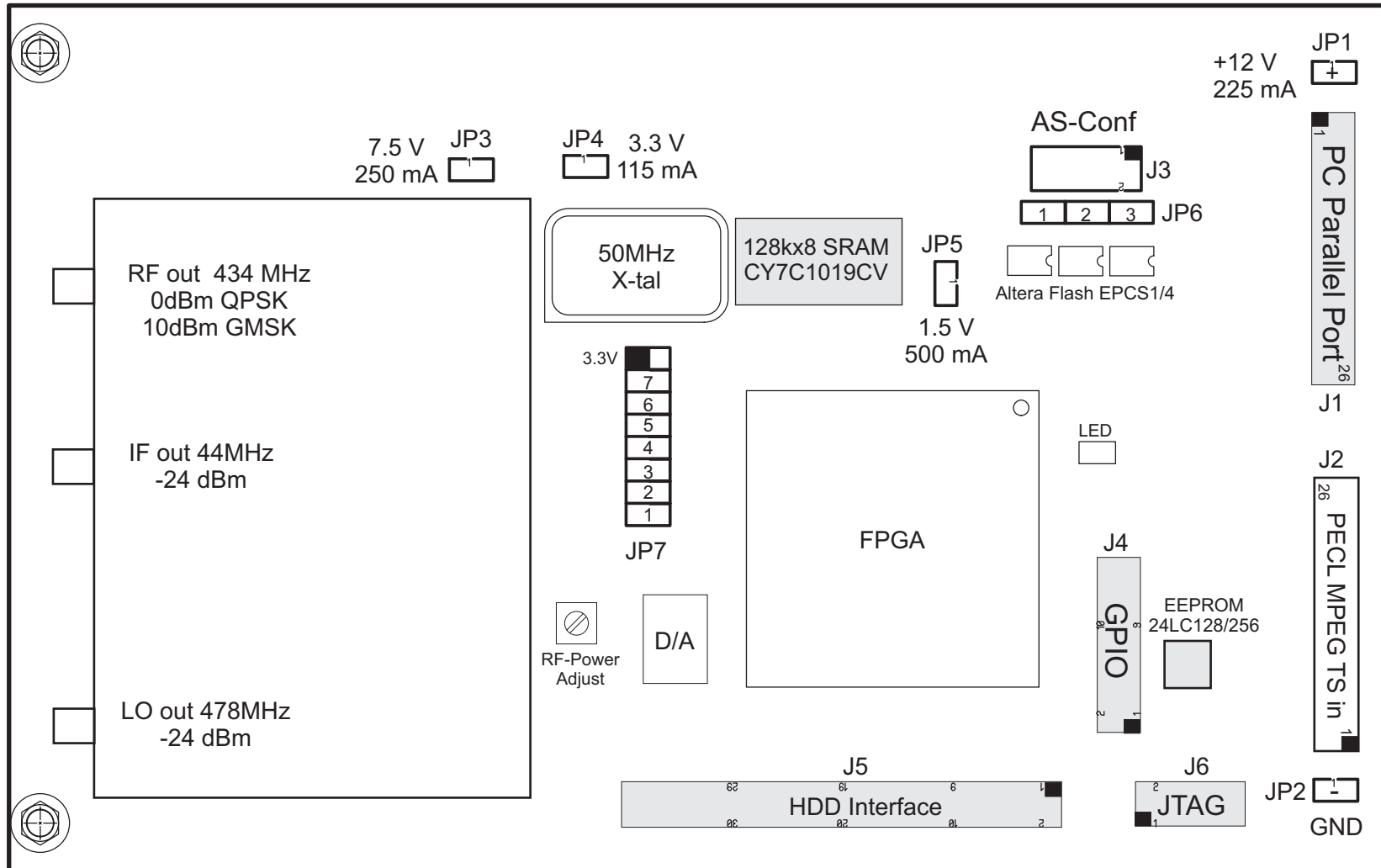

optional

AGAF e.V.

Fig. 2

DATV-Exciter Board

Top View



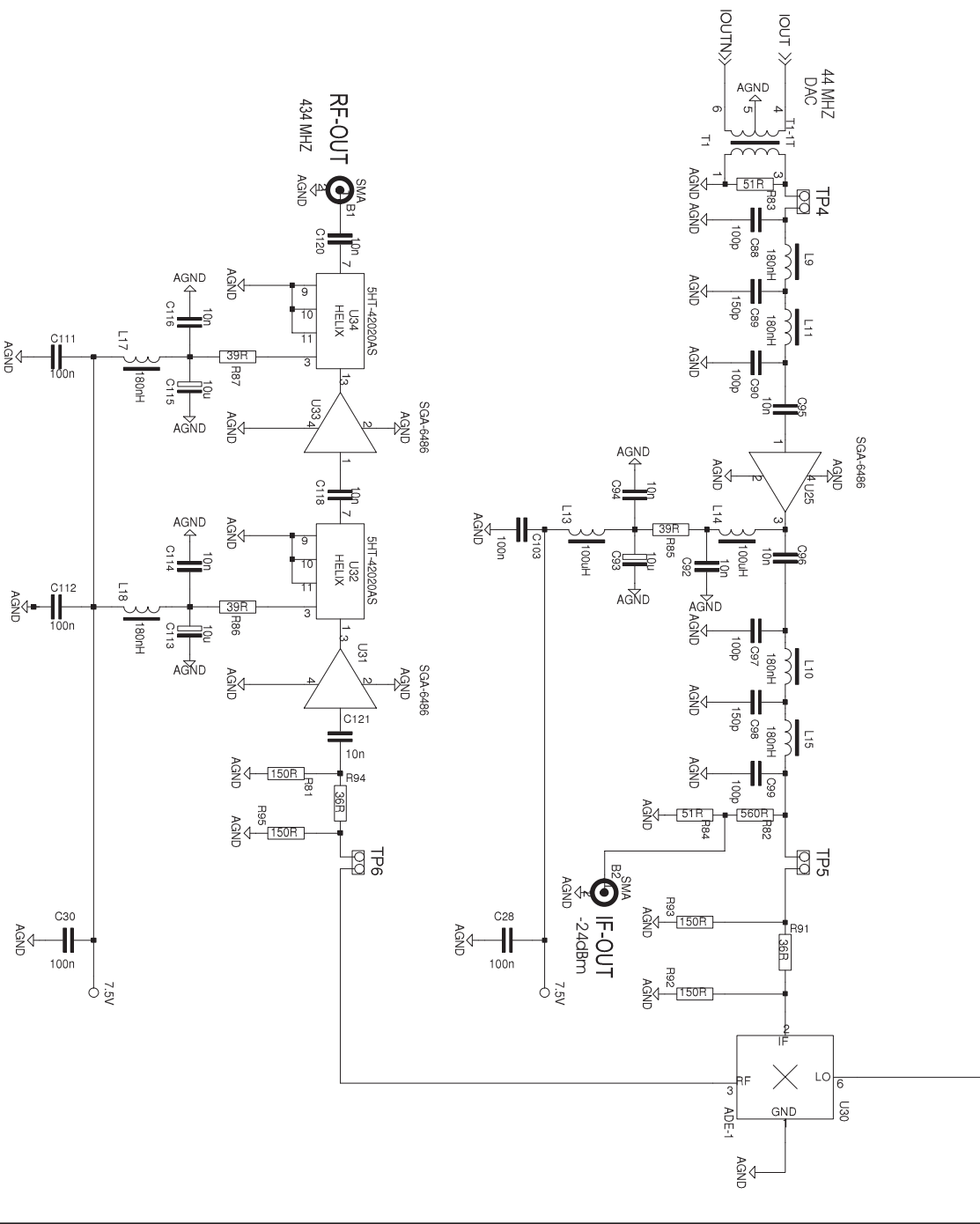
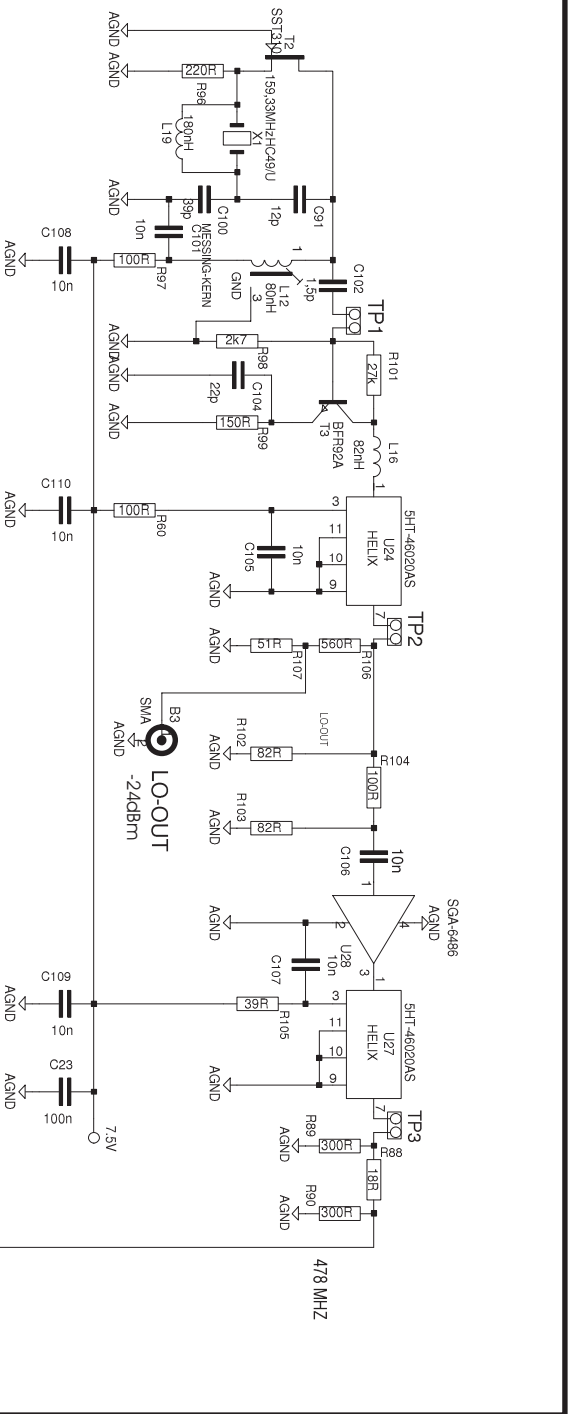

AGAF e.V.
Fig. 3

DATV-Exciter IF/RF-Part



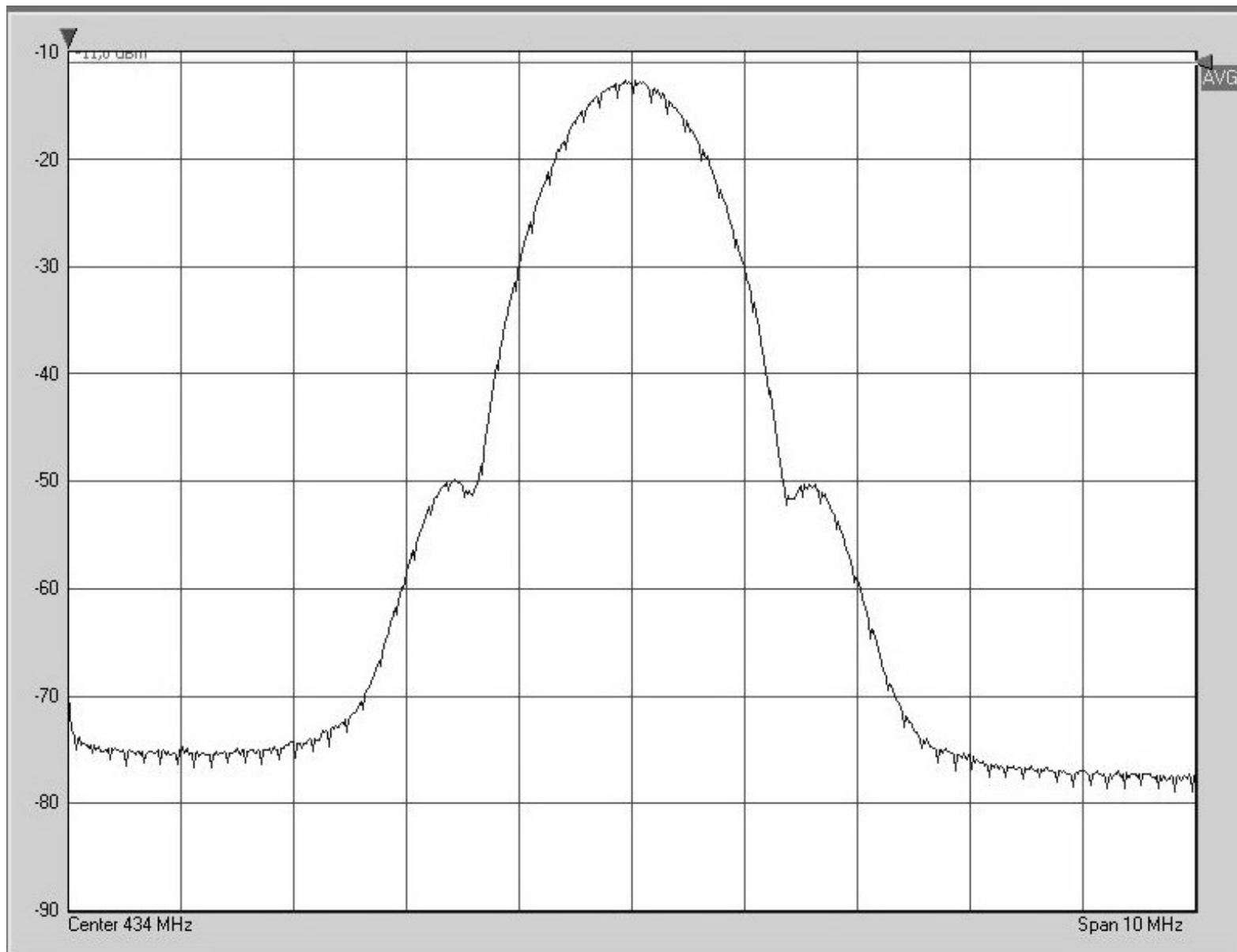

AGAF e.V.

Fig. 4

Spectrum GMSK ca. 2MBit/s



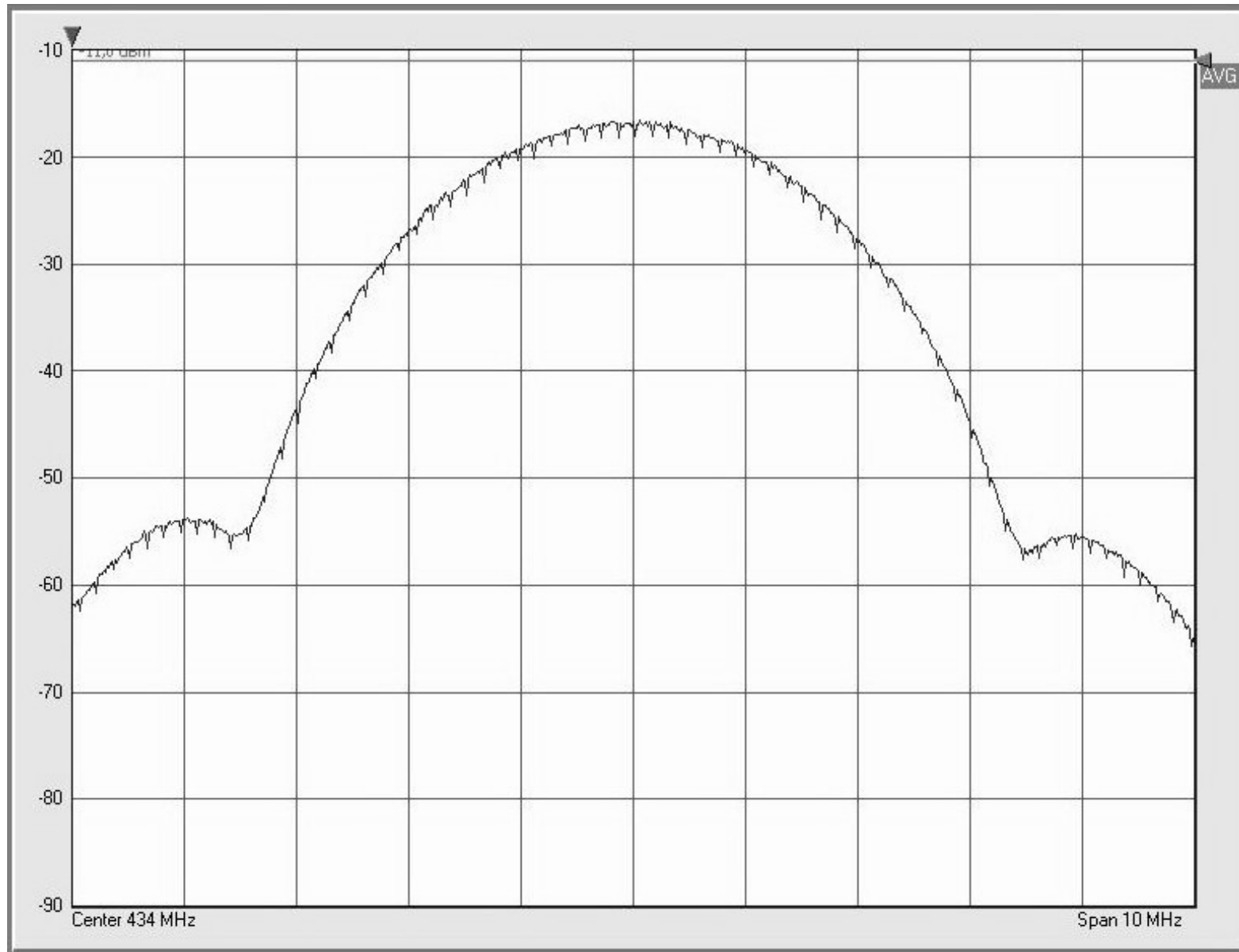

AGAF e.V.

Fig. 5

Spectrum GSMK ca. 5MBit/s



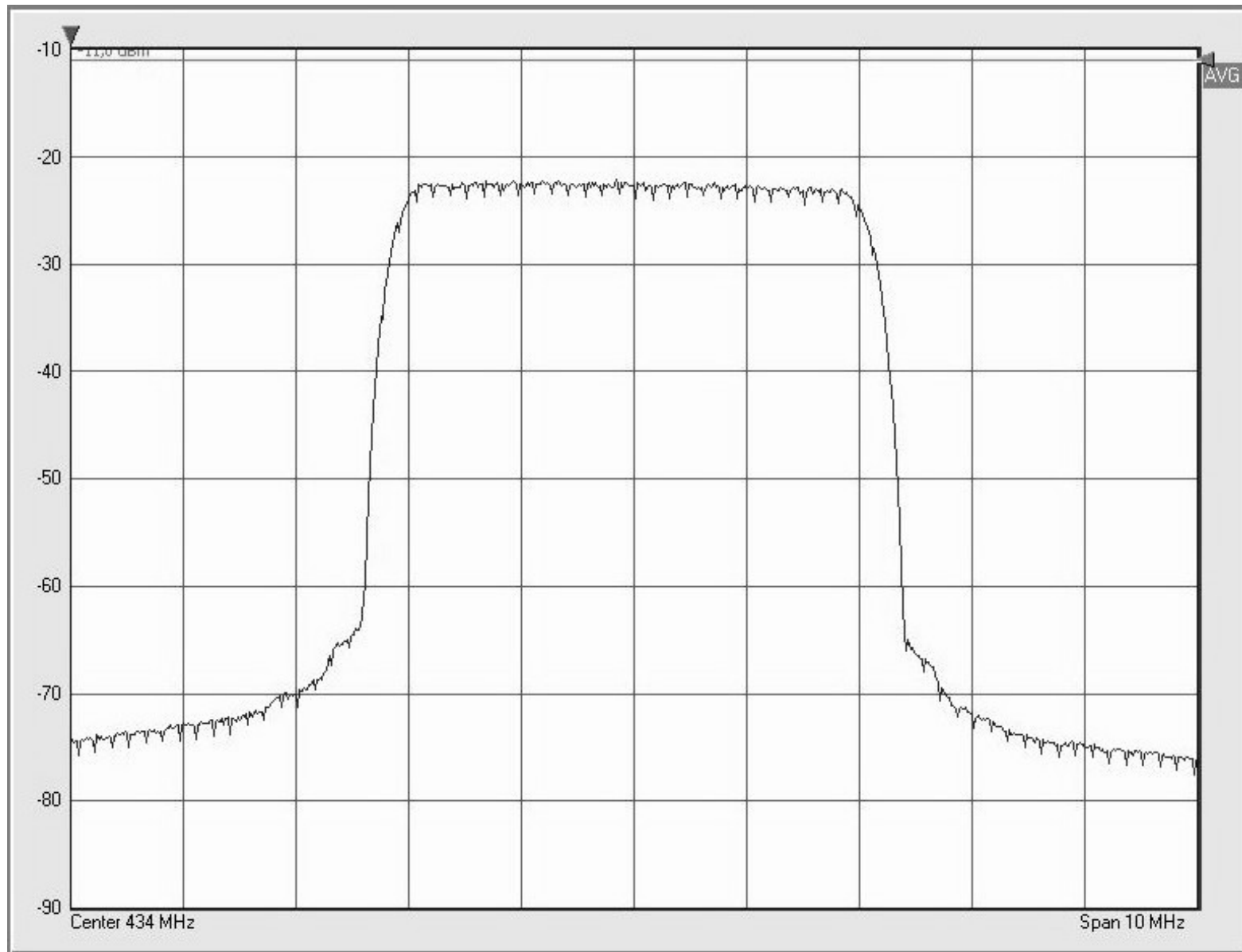

AGAF e.V.

Fig. 6

Spectrum QPSK 4,167MSymb/s



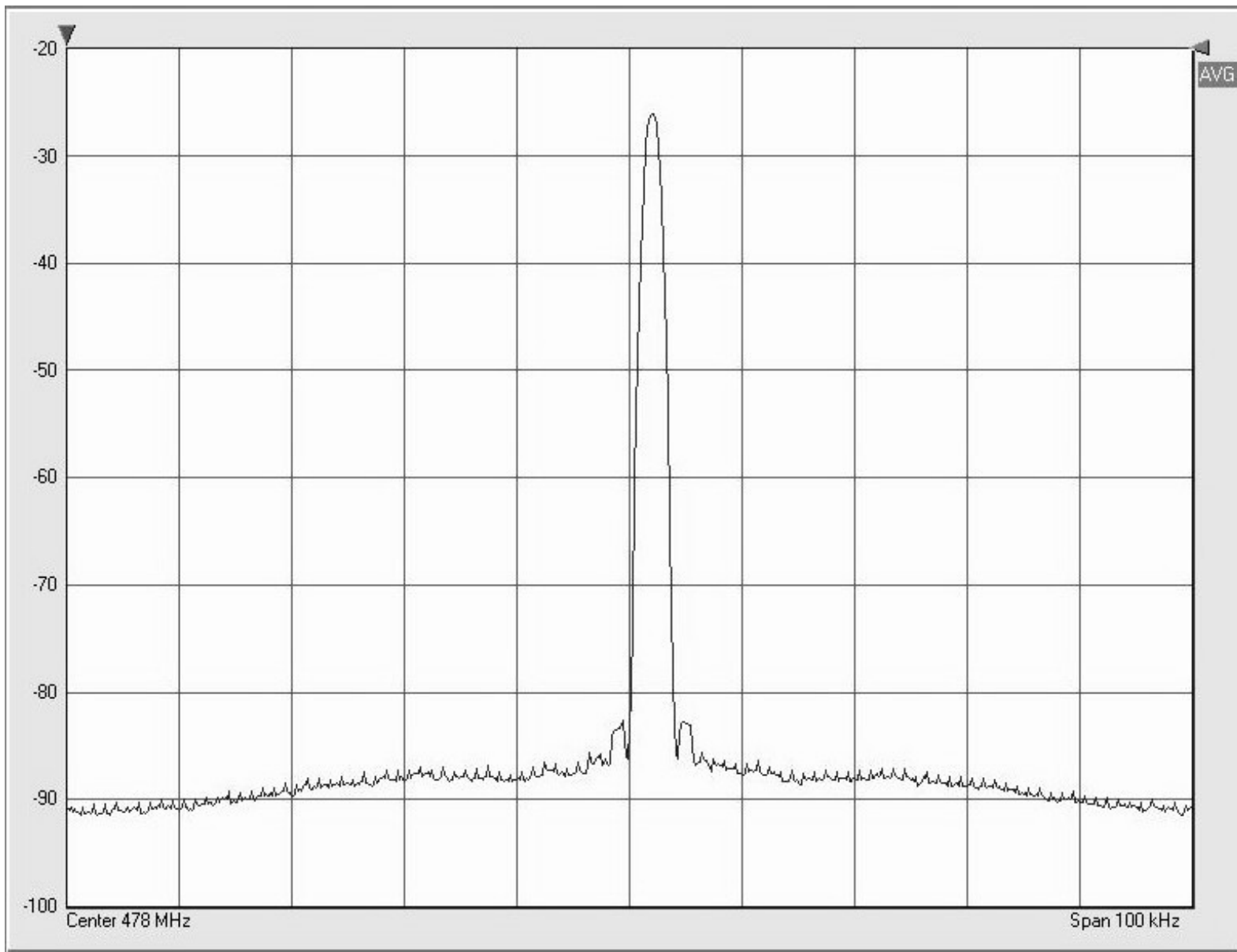

AGAF e.V.

Fig. 7

Spectrum LO 478 MHz

